

SCHOTTKY BARRIER RECTIFIER Reverse Voltage - 35 to 200 Volts Forward Current - 15Amperes

**FEATURES**

- .Plastic package has Underwriters Laboratory Flammability Classification 94V-0
- .Metal silicon junction ,majority carrier conduction
- . Guard ring for over voltage protection
- . Low power loss ,high efficiency
- .High current capability ,Low forward voltage drop
- .High surge capability
- . For use in low voltage ,high frequency inverters, free wheeling ,and polarity protection applications
- . Dual rectifier construction
- . High temperature soldering guaranteed:260°C/10 seconds,0.25"(6.35mm)from case
- . Component in accordance to RoHS 2002/95/EC and WEEE2002/96/EC

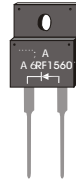

**ITO-220AC**

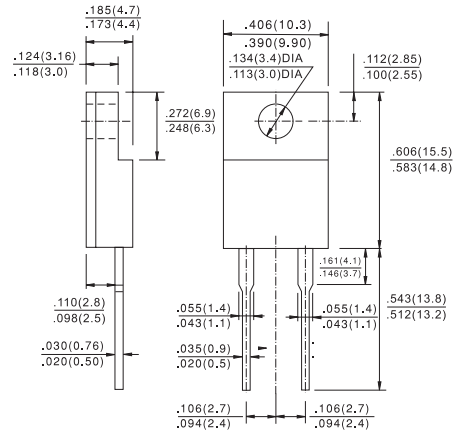

**MECHANICAL DATA**

Case:JEDEC ITO-220AC molded plastic body  
 Terminals:Lead solderable per MIL-STD-750,method 2026P  
 Polarity: As marked.Mounting P  
 Position:AnyWeight:0.08ounce, 2.24 gram

Dimensions in inches and (millimeters)

**MAXIMUM RATINGS AND ELECTRICAL CHARACTERISTICS**

(Ratings at 25 C ambient temperature unless otherwise specified ,Single phase ,half wave ,resistive or inductive load. For capacitive load, derate by 20%.)

	Symbols	MBRF1535	MBRF1545	MBRF1550	MBRF1560	MBRF15100	MBRF15150	MBRF15200	Units
Maximum repetitive peak reverse voltage	VRRM	35	45	50	60	100	150	200	Volts
Maximum RMS voltage	VRMS	25	32	35	42	70	105	140	Volts
Maximum DC blocking voltage	VDC	35	45	50	60	100	150	200	Volts
Maximum average forward rectified current	Per leg	7.5							Amps
	Total device	15.0							
Peak forward surge current 8.3ms single half sine-wave superimposed on rated load (JEDEC method)	IFSM	150							Amps
Maximum instantaneous forward voltage at 15 A	VF	0.6	0.75	0.85	0.9	0.95			Volts
Maximum instantaneous reverse current at rated DC blocking voltage(Note 1)	TC = 25 C	0.2							mA
	TC = 125 C	30	50						
Typical thermal resistance (Note 2)	RJC	3							C/W
Operating junction temperature range	TJ	-65 to+ 150							C
Storage temperature range	TSTG	-65 to+ 150							C

**Notes:**

- 1.Pulse test: 300 s pulse width,1% duty cycle(Ratings at 25 C ambient temperature unless otherwise specified ,Single phase ,half wave ,resistive or inductive load. For capacitive load, derate by 20%.)
- 2.Thermal resistance from junction to case

FIG.1-FORWARD CURRENT DERATING CURVE

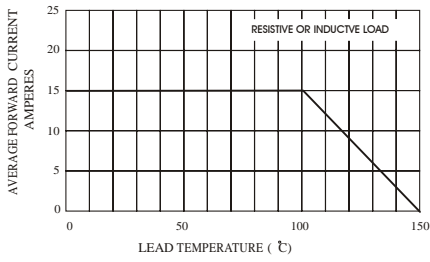

FIG.2-MAXIMUM NON-REPETITIVE PEAK FORWARD SURGE CURRENT

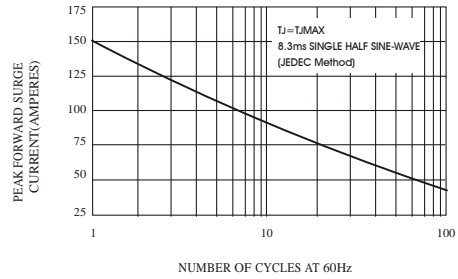

FIG.3-TYPICAL INSTANTANEOUS FORWARD CHARACTERISTICS

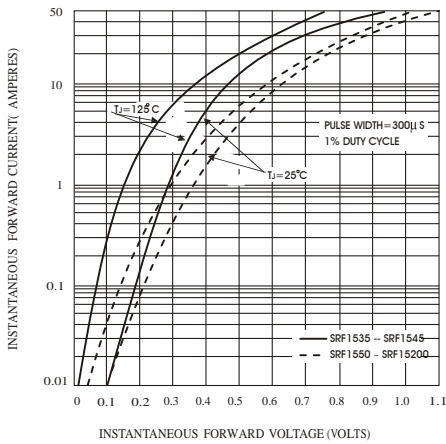

FIG.4-TYPICAL REVERSE CHARACTERISTICS

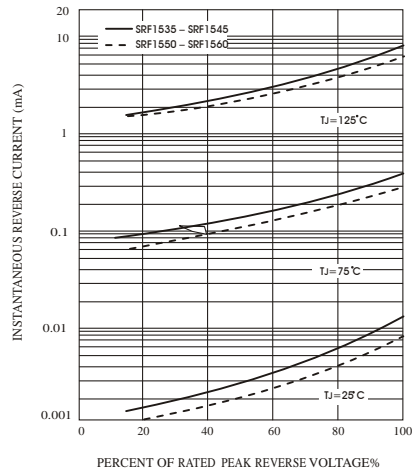

FIG.5-TYPICAL JUNCTION CAPACITANCE

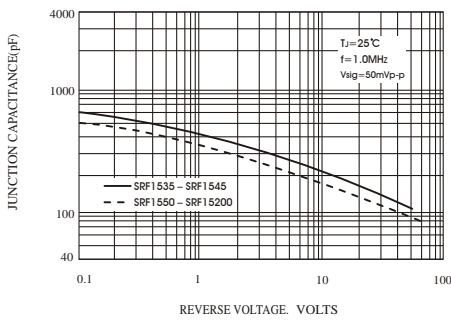

FIG.6-TYPICAL TRANSIENT THERMAL IMPEDANCE

